

O & M INSTRUCTION

PRODUCT GROUP 1911 - ELECTRONIC SPEED CONTROLLER IM/BP

Safety

This is an electrical product, and all power to the device should be isolated prior to removing any covers or wiring.

This work must be performed by a suitably qualified person.

Installation and Operation Instructions for Model IM

1. Check the maximum current drawn by the fan does not exceed the rating of the speed controller.
2. Install in clean, dry conditions. Leave a space at least 150mm around the controller to allow cooling air to flow freely. The maximum ambient temperature should not exceed 50 degrees centigrade.
3. Automatic two speed operation can be achieved by the addition of an external switch contacts closed and a second speed pre-set by the controller when the switch is open. Connect the switch U and Z terminals of the controller as shown in the diagram.
4. Electrical connections should be carried out by a suitably qualified person and comply with the relevant requirements of the I.E.E.E. wiring regulations or other safety requirements applicable to the site.
5. The speed controller must be earthed.
6. All controllers are fitted with a separate ON/OFF Switch. Rotating the control knob clockwise will increase fan speed.

Note

A. Replacement fuses should be ceramic 20mm 5 amp for the 3 amp controller, 32mm 10 amp for the 6 amp controller, and ceramic 32mm 16 amp for the 10 amp controller.

B. All controllers meet the relevant EC Council Directives, Electromagnetic Compatibility Directive (89/336/EEC and amendment 92/31EEC). Applied Harmonised standards in particular, BS EN 50081-1, BS EN 50082-1 : 1998, BS EN 61000-3-2 : 1995

C. Wiring Diagram

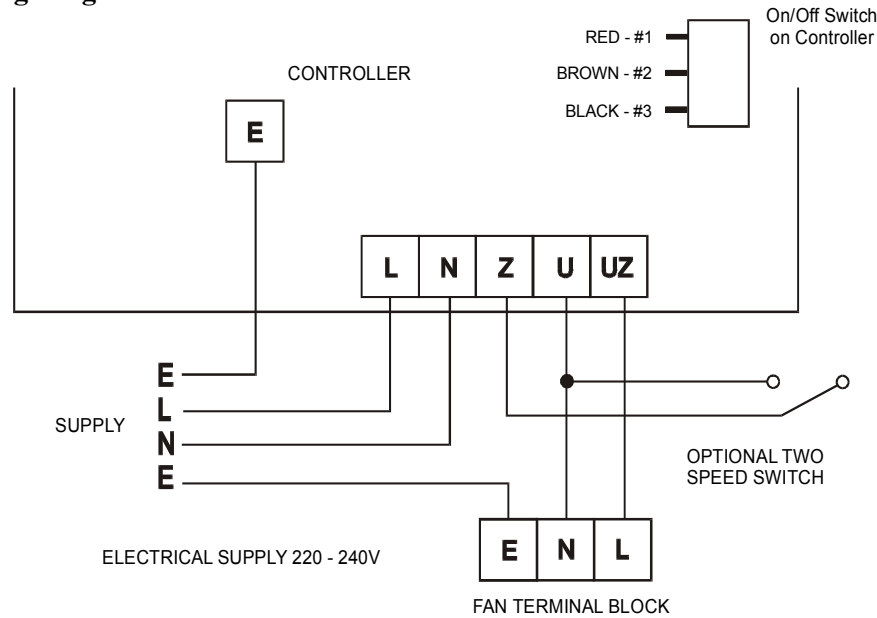

Installation and Operation Instructions For Model BP2, BP3, and BP6

For all applications using suitably specified single phase induction motors.

WARNING

Mains voltage is present. Care must be exercised when setting potentiometers. It is the responsibility of the user to ensure compliance with the Health and Safety at Work Act, 1974.

General

The units utilise triac semi-conductor solid state technology. Thus by manual adjustment of a rotary knob on the front fascia panel, the end user may vary the available power to most permanent split capacitor, shaded pole and Steinmetze motors.

Control is best achieved with propeller, axial or centrifugal fan loads. Motor selection criteria should include that absorbed power at full load is in the range 70% - 97% of the motor's capacity.

MODEL NUMBER	RUN CURRENT (AMPS)	MAXIMUM START CURRENT (AMPS)	FUSE SIZE (AMPS)
BP2	2	4	2.0
BP3	3	6	3.15
BP6	6	12	6.3

Specification

1. The BP2, BP3 and BP6 controls are designed for continuous operation with 2 amp, 3 amp and 6 amp loads respectively at 30 degrees C ambient on single phase 220/240 v 50 HZ supply.
2. The maximum RMS start current for 10 seconds at 30 degrees C is 4 amps for BP2, 6 amps for BP3 and 12 amps for BP6.
3. The normal equipment operating range is 0 degrees C to 40 degrees C. Storage temperature range is -20 degrees C to +60 degrees C.
4. RFI suppression designed to meet BS800 specification.
5. The BP series are housed in plastic boxes with aluminium fascia plates and IP40 rated. The fascia plate acts as a heatsink and is warm under normal operating conditions.

Circuit Board Protection

Fuses in the units are for protection of the controller wiring and components in case of short circuits. They do not afford motor overload protection.

Motor Protection

The installer should provide motor protection as recommended by IEE Regulations.

Controls

1. **On/off switch.** This isolates both the control and the motor from the single phase supply.
2. **Max/Manual switch.** Max position gives continuous full volts to the motor(s). Manual position allows hand speed control via the front panel rotary knob.
3. **The Front Panel Rotary Knob.** This enables the user to vary the fan motor speed from a pre-set minimum to maximum speed.
4. **Minimum Speed.** This internal board mounted control provides minimum speed adjustment to as low as 10% of the maximum rated motor speed. Beware of setting too low a value and risking creating a stall condition.

Wiring the Control

Making connections to the controller as follows:

Terminal No:

Supply Earth
Supply Live
Supply Neutral
Motor Neutral (N)
Motor Live (L2)*
Motor Live (L1), Control Live

***L2 NOT used for two wire motors—use ONLY in 3 wire configuration.**

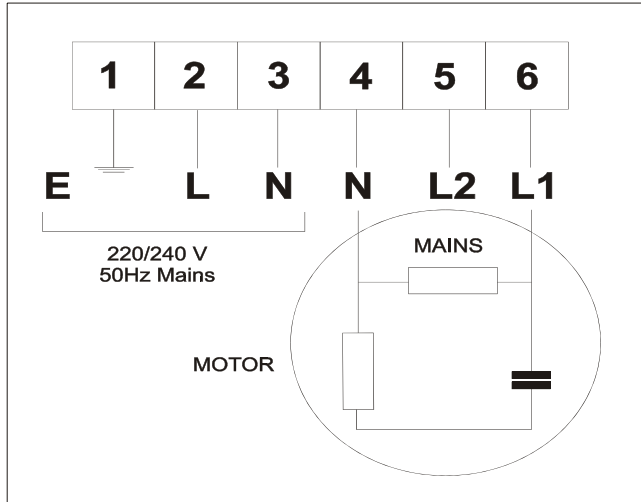

Wiring the Motor

Fan Motor Connection Diagrams

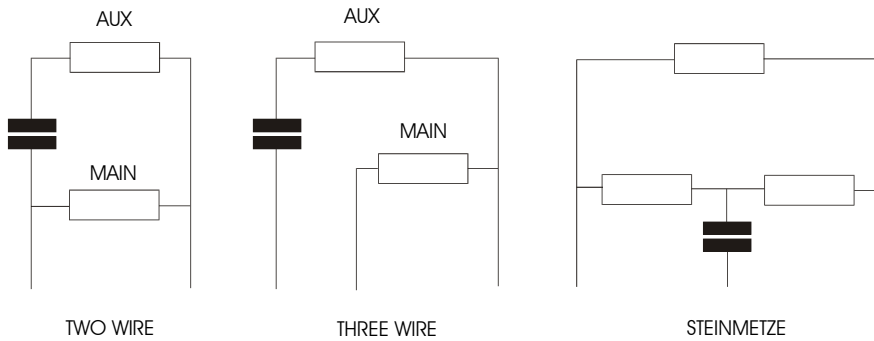

Motor Terminal Connections

A selection of fan motors

Terminal Numbers	Power Supply In/Out	Asea A.B.B	B.C.P. Industrial	Electrodrives101	Engart—B.C.P.	Rosenberg	Solar & Palau	Ventaxia	Woods	Ziehl E.B.M.
1	Earth In/Out									
2	Live Input									
3	Neutral Input									
4	Motor Neutral	U5	UZ	U1	AZ	U1	W	W	UZ	U1
5	Motor Live L2	Z1	Z	4	A	Z	U	U	P	-
6	Motor Live L1	U6	U	U2	B	U2	V	V	U	U2

240V 50hz
Mains Supply

Notes

1. When controlled by triac, many permanent split capacitor fan motors run more smoothly in a three wire configuration and exhibit lower running temperatures and reduced by harmonic hum.
2. **Woods.** Capacitor must be across P and Z not U and Z. Do not link U and P as this causes the fan to run at full speed only.
3. **Engart BCP.** Remove link A-B for speed control.
4. Where motors have wires marked live and neutral, these simply connect to control terminals 4 and 6.

Installation Instructions

1. Connect the unit in accordance with wiring diagrams above.
2. Ensure on/off switch is in “off” position, and max/man switch is in “man” position.
3. Rotate front panel control knob fully anti-clockwise.
4. Energise mains to and switch unit to “on”. The fan runs at full speed for a few seconds (“hard start”) before dropping to minimum speed.
5. If minimum speed is too low, adjust internal minimum speed control until desired minimum is reached. (See CONTROLS—”4”)
6. Rotate front panel knob fully clockwise and check that the fan accelerates to full speed.
7. Setting the max/man switch to “max” operates the fan motor at maximum speed. This overrides the control setting . (See CONTROLS—”2”)

Internal Layout

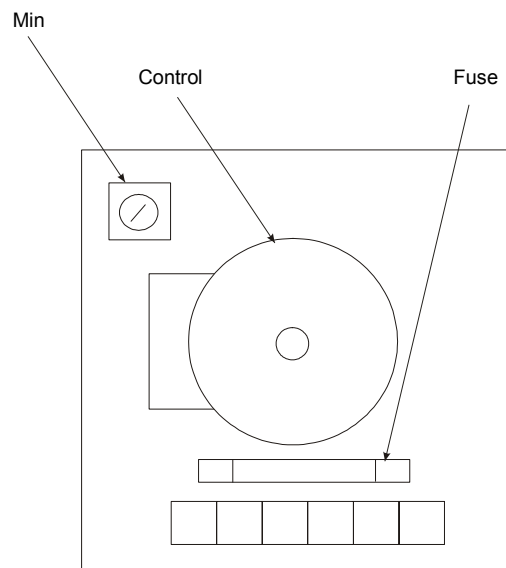

For further information please contact Airclean Ltd.